



# STL6NM60N

N-channel 600 V - 0.85  $\Omega$  - 5.75 A - PowerFLAT™ (5x5)  
ultra low gate charge MDmesh™ II Power MOSFET

## Features

| Type      | V <sub>DSS</sub> @<br>T <sub>JMAX</sub> | R <sub>DS(on)</sub><br>Max | I <sub>D</sub>        |
|-----------|---|----------------------------|-----------------------|
| STL6NM60N | 650 V                                   | < 0.92 $\Omega$            | 5.75 A <sup>(1)</sup> |

1. The value is rated according Rthj-case

- 100% avalanche tested
- Low input capacitance and gate charge
- Low gate input resistance

## Application

- Switching applications

## Description

This series of devices implements the second generation of MDmesh™ Technology. This revolutionary Power MOSFET associates a new vertical structure to the Company's strip layout to yield one of the world's lowest on-resistance and gate charge. It is therefore suitable for the most demanding high efficiency converters.

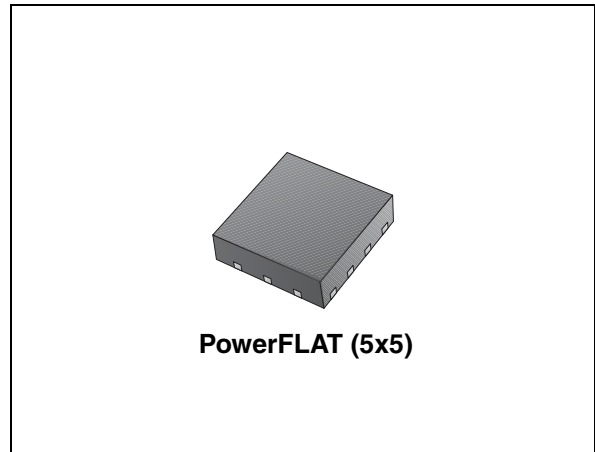

Figure 1. Internal schematic diagram

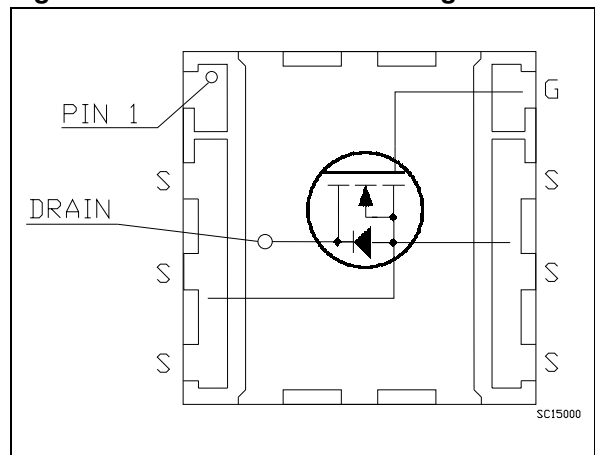

Table 1. Device summary

| Order code | Marking | Package          | Packaging   |
|------------|---------|------------------|-------------|
| STL6NM60N  | L6NM60N | PowerFLAT™ (5x5) | Tape & reel |

## Contents

|          |   |           |
|----------|---|-----------|
| <b>1</b> | <b>Electrical ratings</b> .....               | <b>3</b>  |
| <b>2</b> | <b>Electrical characteristics</b> .....       | <b>4</b>  |
|          | 2.1 Electrical characteristics (curves) ..... | 6         |
| <b>3</b> | <b>Test circuit</b> .....                     | <b>8</b>  |
| <b>4</b> | <b>Package mechanical data</b> .....          | <b>9</b>  |
| <b>5</b> | <b>Revision history</b> .....                 | <b>11</b> |

# 1 Electrical ratings

**Table 2. Absolute maximum ratings**

| Symbol             | Parameter   | Value      | Unit |
|--------------------|---|------------|------|
| $V_{DS}$           | Drain-source voltage ( $V_{GS} = 0$ )   | 600        | V    |
| $V_{GS}$           | Gate-source voltage   | $\pm 25$   | V    |
| $I_D^{(1)}$        | Drain current (continuous) at $T_C = 25\text{ }^\circ\text{C}$ (steady state) | 5.75       | A    |
| $I_D^{(1)}$        | Drain current (continuous) at $T_C = 100\text{ }^\circ\text{C}$               | 3.62       | A    |
| $I_{DM}^{(1),(2)}$ | Drain current (pulsed)  | 23         | A    |
| $I_D^{(3)}$        | Drain current (continuous) at $T_C = 25\text{ }^\circ\text{C}$                | 1          | A    |
| $I_D^{(3)}$        | Drain current (continuous) at $T_C = 100\text{ }^\circ\text{C}$               | 0.65       | A    |
| $I_{DM}^{(2),(3)}$ | Drain current (pulsed)  | 4          | A    |
| $P_{TOT}^{(3)}$    | Total dissipation at $T_C = 25\text{ }^\circ\text{C}$ (steady state)          | 2.1        | W    |
| $P_{TOT}^{(1)}$    | Total dissipation at $T_C = 25\text{ }^\circ\text{C}$ (steady state)          | 70         | W    |
|                    | Derating factor <sup>(3)</sup>  | 0.02       | W/°C |
| $dv/dt^{(4)}$      | Peak diode recovery voltage slope   | 5          | V/ns |
| $T_J$<br>$T_{stg}$ | Operating junction temperature<br>storage temperature                         | -55 to 150 | °C   |

1. The value is rated according Rthj-case
2. Pulse width limited by safe operating area.
3. When mounted on FR-4 board of 1inch<sup>2</sup>, 2oz Cu
4.  $I_{SD} \leq 4.6\text{A}$ ,  $dv/dt \leq 400\text{A}/\mu\text{s}$ ,  $V_{DD} = 80\%V_{(BR)DSS}$

**Table 3. Thermal resistance**

| Symbol              | Parameter                        | Typ  | Max  | Unit |
|---------------------|----------------------------------|------|------|------|
| $R_{thj-case}$      | Thermal resistance junction-case | --   | 1.8  | °C/W |
| $R_{thj-pcb}^{(1)}$ | Thermal resistance junction-pcb  | 31.2 | 58.5 | °C/W |

1. When mounted on FR-4 board of 1inch<sup>2</sup>, 2oz Cu,  $t < 10\text{ sec}$

**Table 4. Avalanche characteristics**

| Symbol   | Parameter  | Typ | Unit |
|----------|--|-----|------|
| $I_{AS}$ | Avalanche current, repetitive or not-repetitive <sup>(1)</sup> | 2   | A    |
| $E_{AS}$ | Single pulse avalanche energy <sup>(2)</sup>                   | 65  | mJ   |

1. Pulse width limited by  $T_{jmax}$
2. Starting  $T_j = 25\text{ }^\circ\text{C}$ ,  $I_D = I_{AS}$ ,  $V_{DD} = 50\text{ V}$

## 2 Electrical characteristics

( $T_{CASE}=25^{\circ}C$  unless otherwise specified)

**Table 5. On/off states**

| Symbol        | Parameter  | Test conditions   | Min. | Typ. | Max.      | Unit                           |
|---------------|--|---|------|------|-----------|--------------------------------|
| $V_{(BR)DSS}$ | Drain-source breakdown voltage                   | $I_D = 1 \text{ mA}, V_{GS} = 0$  | 600  |      |           | V                              |
| $dv/dt^{(1)}$ | Drain-source voltage slope                       | $V_{DD} = 480 \text{ V}, V_{GS} = 10 \text{ V}, I_D = 4.6 \text{ A}$    |      | 40   |           | V/ns                           |
| $I_{DSS}$     | Zero gate voltage drain current ( $V_{GS} = 0$ ) | $V_{DS} = \text{Max rating}, V_{DS} = \text{Max rating} @ 125^{\circ}C$ |      |      | 1<br>100  | $\mu\text{A}$<br>$\mu\text{A}$ |
| $I_{GSS}$     | Gate body leakage current ( $V_{DS} = 0$ )       | $V_{GS} = \pm 20 \text{ V}$   |      |      | $\pm 100$ | nA                             |
| $V_{GS(th)}$  | Gate threshold voltage                           | $V_{DS} = V_{GS}, I_D = 250 \mu\text{A}$                                | 2    | 3    | 4         | V                              |
| $R_{DS(on)}$  | Static drain-source on resistance                | $V_{GS} = 10 \text{ V}, I_D = 2.3 \text{ A}$                            |      | 0.85 | 0.92      | $\Omega$                       |

1. Characteristics value at turn off on inductive load

**Table 6. Dynamic**

| Symbol                      | Parameter                     | Test conditions   | Min. | Typ. | Max. | Unit     |
|-----------------------------|-------------------------------|---|------|------|------|----------|
| $g_{fs}^{(1)}$              | Forward transconductance      | $V_{DS} = 15 \text{ V}, I_D = 2.3 \text{ A}$                                  |      | 4    |      | S        |
| $C_{iss}$                   | Input capacitance             | $V_{DS} = 50 \text{ V}, f = 1 \text{ MHz}, V_{GS} = 0$                        |      | 420  |      | pF       |
| $C_{oss}$                   | Output capacitance            |   |      | 30   |      | pF       |
| $C_{rss}$                   | Reverse transfer capacitance  |   |      | 4    |      | pF       |
| $C_{oss \text{ eq.}}^{(2)}$ | Output equivalent capacitance | $V_{GS} = 0, V_{DS} = 0 \text{ to } 480 \text{ V}$                            |      | 70   |      | pF       |
| Rg                          | Gate input resistance         | $f = 1 \text{ MHz}$ Gate DC Bias=0<br>test signal level = 20 mV<br>open drain |      | 6    |      | $\Omega$ |
| $Q_g$                       | Total gate charge             | $V_{DD} = 480 \text{ V}, I_D = 4.6 \text{ A}$                                 |      | 13   |      | nC       |
| $Q_{gs}$                    | Gate-source charge            | $V_{GS} = 10 \text{ V}$   |      | 2    |      | nC       |
| $Q_{gd}$                    | Gate-drain charge             | (see Figure 15)   |      | 7    |      | nC       |

1. Pulsed: pulse duration= 300  $\mu\text{s}$ , duty cycle 1.5%

2.  $C_{oss \text{ eq.}}$  is defined as a constant equivalent capacitance giving the same charging time as  $C_{oss}$  when  $V_{DS}$  increases from 0 to 80%  $V_{DSS}$

**Table 7. Switching times**

| Symbol       | Parameter           | Test conditions   | Min. | Typ. | Max. | Unit |
|--------------|---------------------|---|------|------|------|------|
| $t_{d(on)}$  | Turn-on delay time  | $V_{DD} = 300\text{ V}$ , $I_D = 2.3\text{ A}$ ,<br>$R_G = 4.7\ \Omega$ , $V_{GS} = 10\text{ V}$<br>(see Figure 14) |      | 10   |      | ns   |
| $t_r$        | Rise time           |   |      | 8    |      | ns   |
| $t_{d(off)}$ | Turn-off delay time |   |      | 40   |      | ns   |
| $t_f$        | Fall time           |   |      | 9    |      | ns   |

**Table 8. Source drain diode**

| Symbol             | Parameter                     | Test conditions  | Min | Typ. | Max | Unit |
|--------------------|-------------------------------|--|-----|------|-----|------|
| $I_{SD}$           | Source-drain current          |  |     |      | 1   | A    |
| $I_{SDM}^{(1)(2)}$ | Source-drain current (pulsed) |  |     |      | 4   | A    |
| $V_{SD}^{(3)}$     | Forward on voltage            | $I_{SD} = 4.6\text{ A}$ , $V_{GS} = 0$   |     |      | 1.3 | V    |
| $t_{rr}$           | Reverse recovery time         | $I_{SD} = 4.6\text{ A}$ ,<br>$di/dt = 100\text{ A}/\mu\text{s}$ ,<br>$V_{DD} = 20\text{ V}$<br>(see Figure 16)                                     |     | 300  |     | ns   |
| $Q_{rr}$           | Reverse recovery charge       |  |     | 2    |     | nC   |
| $I_{RRM}$          | Reverse recovery current      |  |     | 12   |     | A    |
| $t_{rr}$           | Reverse recovery time         | $I_{SD} = 4.6\text{ A}$ ,<br>$di/dt = 100\text{ A}/\mu\text{s}$ ,<br>$V_{DD} = 20\text{ V}$ , $T_j = 150\text{ }^\circ\text{C}$<br>(see Figure 16) |     | 470  |     | ns   |
| $Q_{rr}$           | Reverse recovery charge       |  |     | 3    |     | nC   |
| $I_{RRM}$          | Reverse recovery current      |  |     | 12   |     | A    |

1. Pulse width limited by safe operating area
2. When mounted on FR-4 board of 1inch<sup>2</sup>, 2oz Cu
3. Pulsed: pulse duration=300 $\mu\text{s}$ , duty cycle 1.5%

## 2.1 Electrical characteristics (curves)

Figure 2. Safe operating area

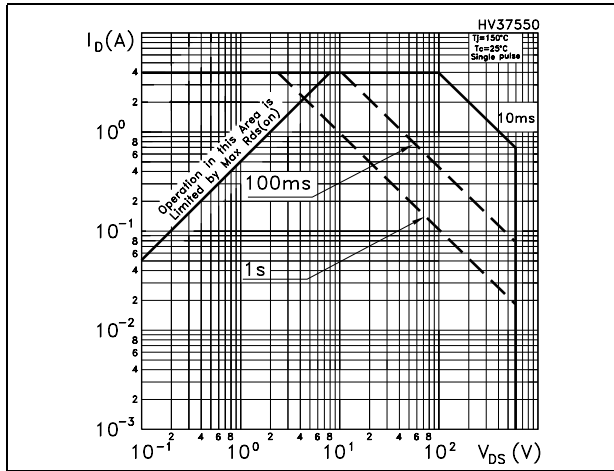

Figure 3. Thermal impedance

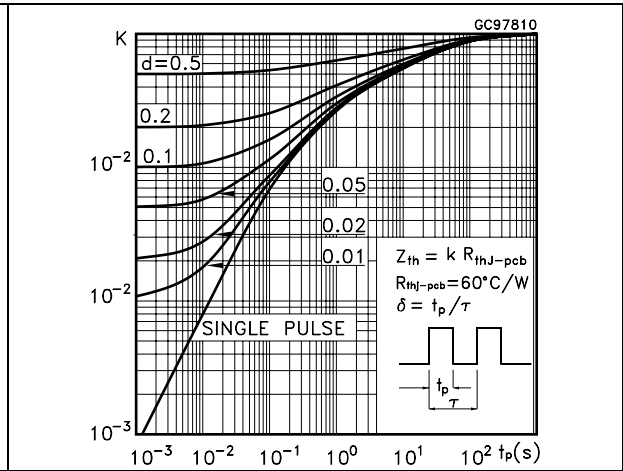

Figure 4. Output characteristics

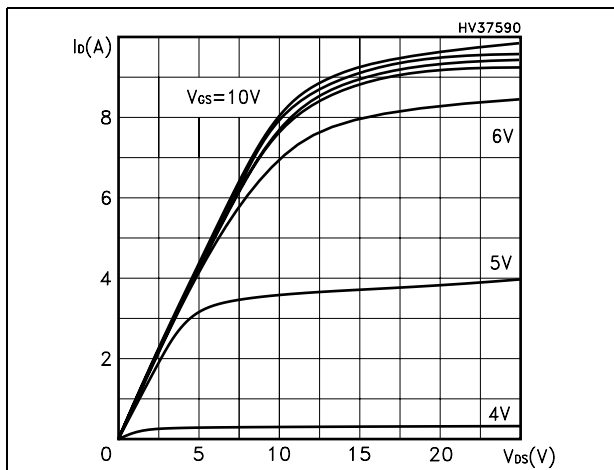

Figure 5. Transfer characteristics

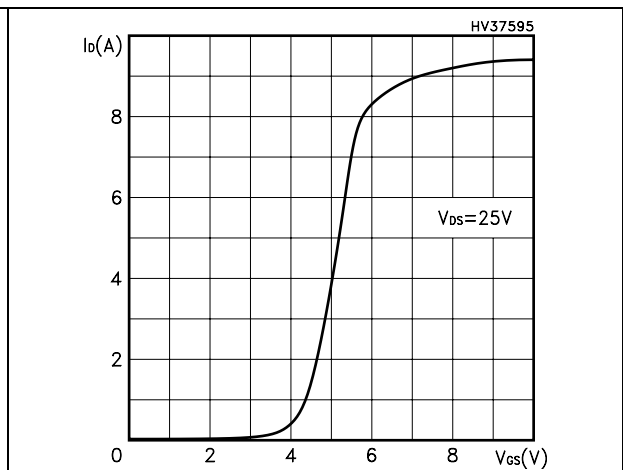

Figure 6. Transconductance

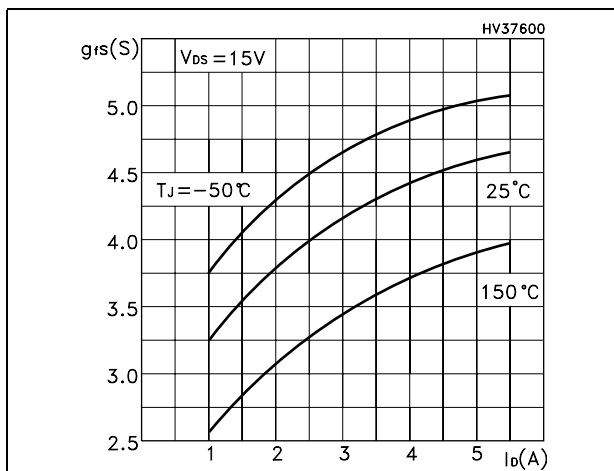

Figure 7. Static drain-source on resistance

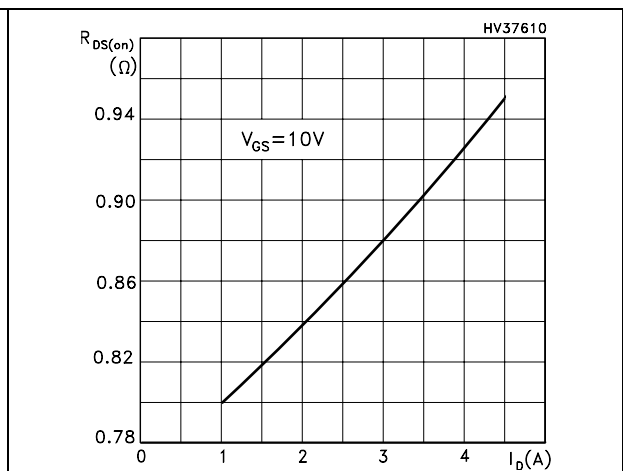

Figure 8. Gate charge vs gate-source voltage Figure 9. Capacitance variations

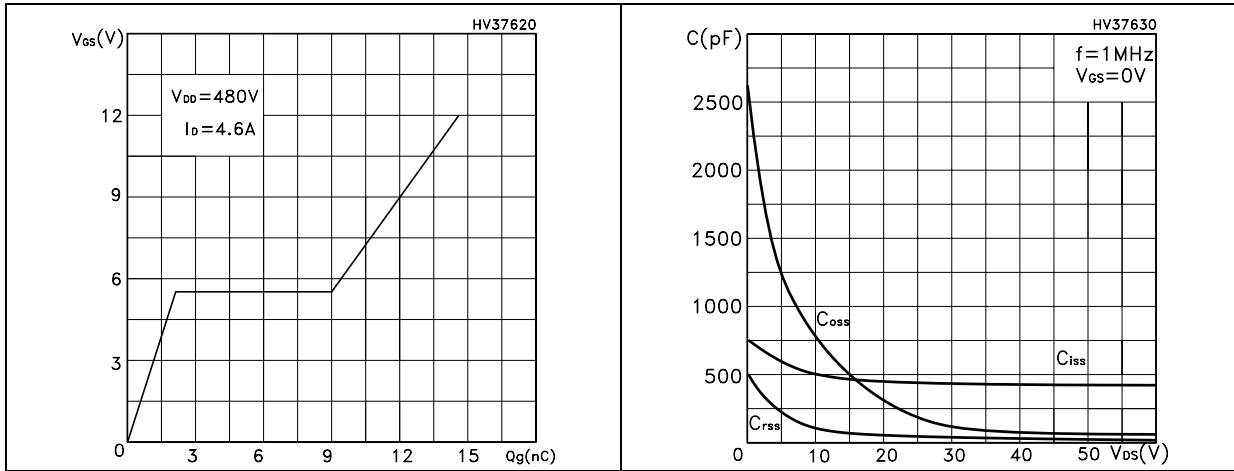

Figure 10. Normalized gate threshold voltage vs temperature

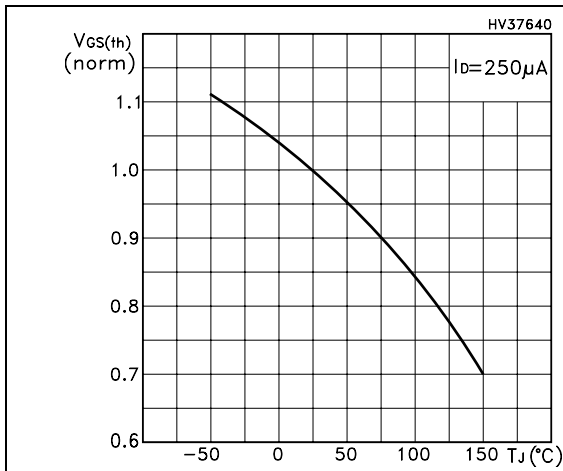

Figure 11. Normalized on resistance vs temperature

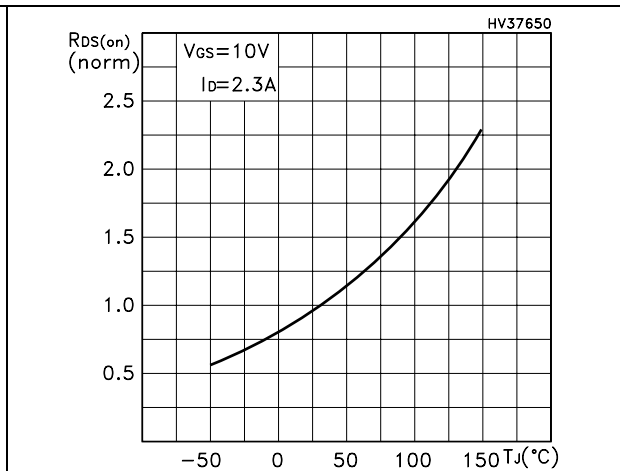

Figure 12. Source-drain diode forward characteristics

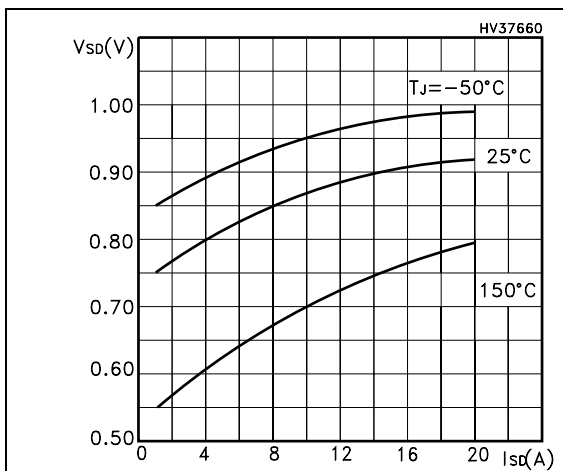
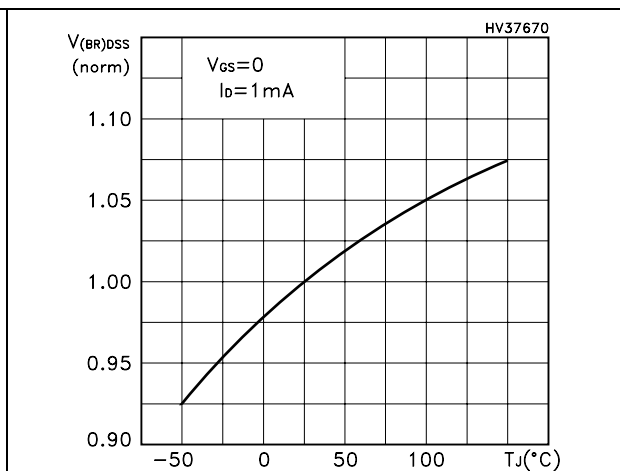

Figure 13. Normalized  $B_{V_{DS}}$  vs temperature



### 3 Test circuit

Figure 14. Switching times test circuit for resistive load

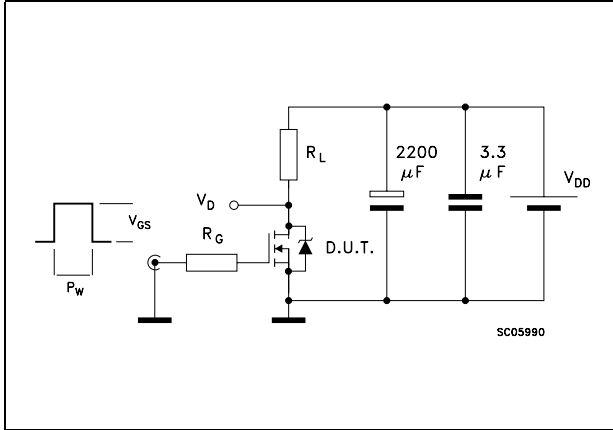

Figure 15. Gate charge test circuit

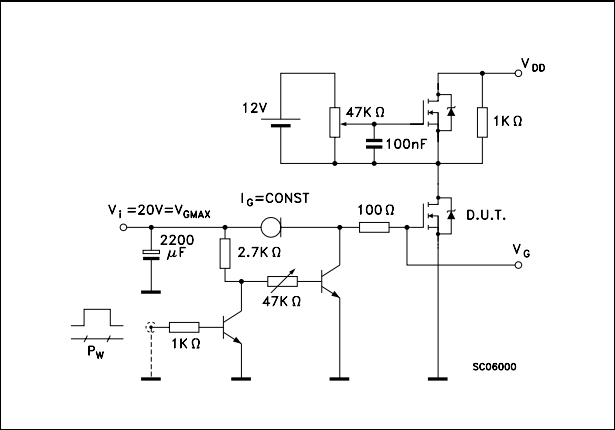

Figure 16. Test circuit for inductive load switching and diode recovery times

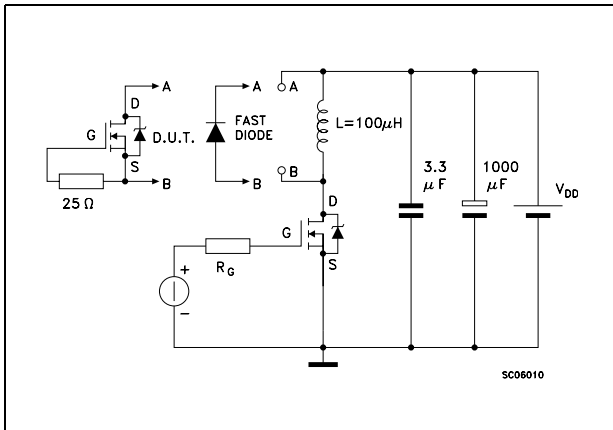

Figure 17. Unclamped inductive load test circuit

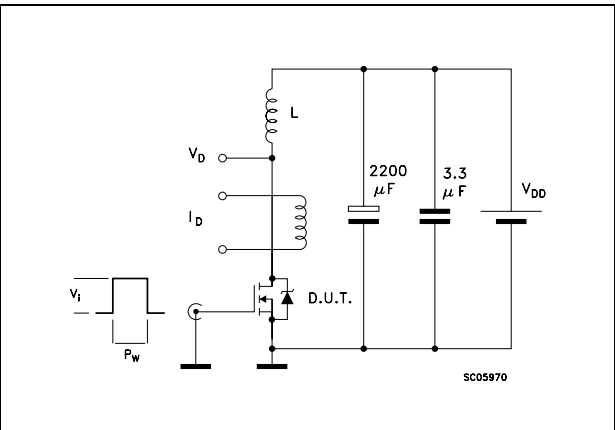

Figure 18. Unclamped inductive waveform

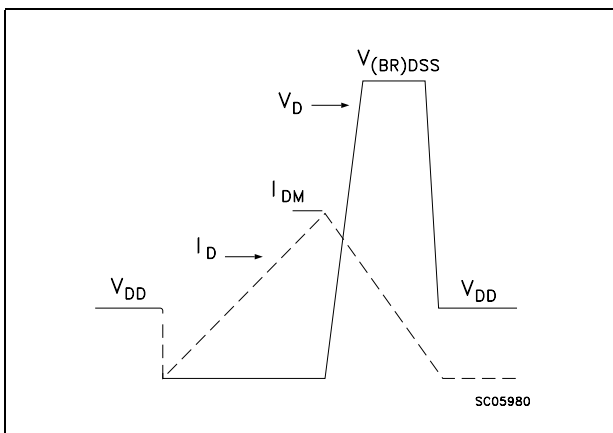
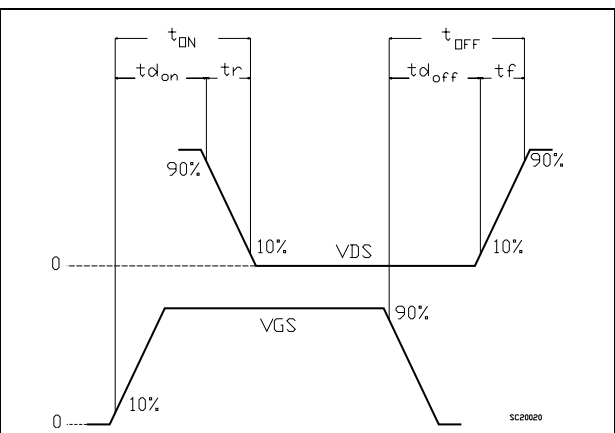

Figure 19. Switching time waveform





## 4 Package mechanical data

In order to meet environmental requirements, ST offers these devices in ECOPACK® packages. These packages have a Lead-free second level interconnect. The category of second level interconnect is marked on the package and on the inner box label, in compliance with JEDEC Standard JESD97. The maximum ratings related to soldering conditions are also marked on the inner box label. ECOPACK is an ST trademark. ECOPACK specifications are available at: [www.st.com](http://www.st.com)

**PowerFLAT™(5x5) MECHANICAL DATA**

| DIM. | mm.  |      |      | inch  |        |       |
|------|------|------|------|-------|--------|-------|
|      | MIN. | TYP. | MAX. | MIN.  | TYP.   | MAX.  |
| A    | 0.80 | 0.90 | 1.00 | 0.031 | 0.035  | 0.039 |
| A1   |      | 0.02 | 0.05 |       | 0.0007 | 0.002 |
| A3   |      | 0.24 |      |       | 0.009  |       |
| b    | 0.43 | 0.51 | 0.58 | 0.016 | 0.020  | 0.022 |
| c    | 0.64 | 0.71 | 0.79 | 0.025 | 0.027  | 0.031 |
| D    |      | 5.00 |      |       | 0.19   |       |
| E    |      | 5.00 |      |       | 0.19   |       |
| E2   | 2.49 | 2.57 | 2.64 | 0.01  | 0.10   | 0.103 |
| e    |      | 1.27 |      |       | 0.05   |       |

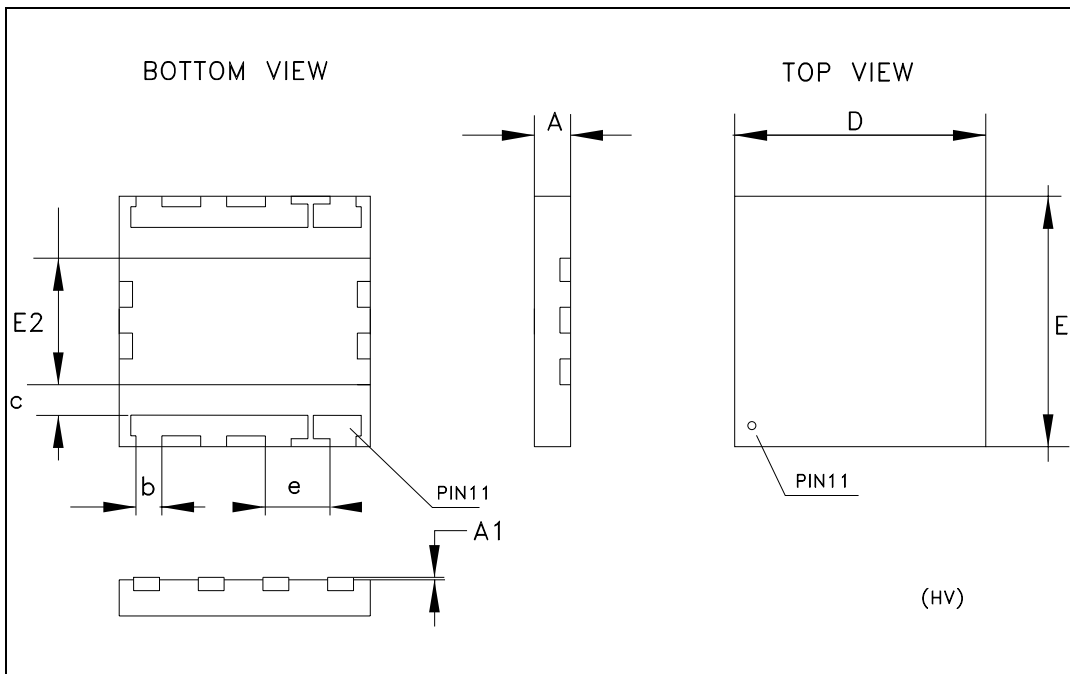

## 5 Revision history

**Table 9. Document revision history**

| Date        | Revision | Changes   |
|-------------|----------|---|
| 04-May-2007 | 1        | First release                                     |
| 23-May-2007 | 2        | Update test conditions on <a href="#">Table 7</a> |
| 27-Nov-2007 | 3        | Mechanical data has been updated                  |

**Please Read Carefully:**

Information in this document is provided solely in connection with ST products. STMicroelectronics NV and its subsidiaries ("ST") reserve the right to make changes, corrections, modifications or improvements, to this document, and the products and services described herein at any time, without notice.

All ST products are sold pursuant to ST's terms and conditions of sale.

Purchasers are solely responsible for the choice, selection and use of the ST products and services described herein, and ST assumes no liability whatsoever relating to the choice, selection or use of the ST products and services described herein.

No license, express or implied, by estoppel or otherwise, to any intellectual property rights is granted under this document. If any part of this document refers to any third party products or services it shall not be deemed a license grant by ST for the use of such third party products or services, or any intellectual property contained therein or considered as a warranty covering the use in any manner whatsoever of such third party products or services or any intellectual property contained therein.

**UNLESS OTHERWISE SET FORTH IN ST'S TERMS AND CONDITIONS OF SALE ST DISCLAIMS ANY EXPRESS OR IMPLIED WARRANTY WITH RESPECT TO THE USE AND/OR SALE OF ST PRODUCTS INCLUDING WITHOUT LIMITATION IMPLIED WARRANTIES OF MERCHANTABILITY, FITNESS FOR A PARTICULAR PURPOSE (AND THEIR EQUIVALENTS UNDER THE LAWS OF ANY JURISDICTION), OR INFRINGEMENT OF ANY PATENT, COPYRIGHT OR OTHER INTELLECTUAL PROPERTY RIGHT.**

**UNLESS EXPRESSLY APPROVED IN WRITING BY AN AUTHORIZED ST REPRESENTATIVE, ST PRODUCTS ARE NOT RECOMMENDED, AUTHORIZED OR WARRANTED FOR USE IN MILITARY, AIR CRAFT, SPACE, LIFE SAVING, OR LIFE SUSTAINING APPLICATIONS, NOR IN PRODUCTS OR SYSTEMS WHERE FAILURE OR MALFUNCTION MAY RESULT IN PERSONAL INJURY, DEATH, OR SEVERE PROPERTY OR ENVIRONMENTAL DAMAGE. ST PRODUCTS WHICH ARE NOT SPECIFIED AS "AUTOMOTIVE GRADE" MAY ONLY BE USED IN AUTOMOTIVE APPLICATIONS AT USER'S OWN RISK.**

Resale of ST products with provisions different from the statements and/or technical features set forth in this document shall immediately void any warranty granted by ST for the ST product or service described herein and shall not create or extend in any manner whatsoever, any liability of ST.

ST and the ST logo are trademarks or registered trademarks of ST in various countries.

Information in this document supersedes and replaces all information previously supplied.

The ST logo is a registered trademark of STMicroelectronics. All other names are the property of their respective owners.

© 2007 STMicroelectronics - All rights reserved

STMicroelectronics group of companies

Australia - Belgium - Brazil - Canada - China - Czech Republic - Finland - France - Germany - Hong Kong - India - Israel - Italy - Japan - Malaysia - Malta - Morocco - Singapore - Spain - Sweden - Switzerland - United Kingdom - United States of America

[www.st.com](http://www.st.com)